

WHEELER®



ALUMINUM

9900



7700



3900



	9900	7700	3900
AUSSTATTUNG	SHIMANO DEORE XT STI 21 sp	SHIMANO DEORE DX STI 21 sp	SHIMANO 300LX STI
RAHMEN	ALUMINUM 7000 "Box stays", O.S. Tubing	ALUMINUM 7000, O.S. Tubing "Box Chain Stays"	ALUMINUM Oversize Sloping
GABEL	RESPONSE/TANGE O.S. Cr-Mo CP	RESPONSE/TANGE O.S., Even Radius Blades	Oversize 1 1/8" Blade
SCHALTGRUPPE	DEORE XT STI, Rapid Fire	DEORE DX STI, Rapid Fire	300LX STI, Rapid Fire
TRETLAGER	DEORE XT 46/36/24T Round, SUPERGLIDE	DEORE DX 46/36/24T Round, SUPERGLIDE	300LX 48/36/28T, 170mm SUPERGLIDE
ZAHNKRANZ	HYPERGLIDE 13-30T, 7s	HYPERGLIDE 13-30T, 7s	Cassette 12-28T Hyperglide
PEDALE	DEORE XT Super Low Profile, Clips/Straps	WHEELER "Comp" Alloy, Clips/Straps	Resin monoblock, Cr-Mo spindle
NABEN	DEORE XT	DEORE DX	SHIMANO Qr.
FELGEN	ARAYA RM-17, Super Hard Anodized, 36H	ARAYA CV-7, Anodized, 36H	ALUMINUM, BLACK (Japan)
BEREIFUNG	WHEELER "Mud Master" 26x2.00"	WHEELER "Mud Master" 26x2.00"	MTB SKINWALL 26x1.95
SPEICHEN	Stainless	Stainless	Stainless
BREMSEN	DEORE XT F/Canti, R/U-Brake, 2 finger lever	DEORE DX Low Profile Canti, 2 finger lever	SHIMANO canti 3 finger levers
STEUERSATZ	WHEELER "Ultra Steer" Oversize Alloy	WHEELER "Ultra Steer" Oversize Alloy 28.6mm	Oversized Steel, Off-road type Cr-mo 6 deg.
LENKERBUEGEL	WHEELER "Super Light" Special Alloy 560mm	WHEELER "Super Light" Special Alloy 560mm	Cr-mo
LENKERVORBAU	ALUTRAX Alloy Superlight T.I.G.	ULTRAX Cr-Mo oversize T.I.G.	Cr-Mo oversize
LENKERGRIFFE	WHEELER Control Grips	WHEELER Control Grips	PVC
SATTEL	SCHNEIDER Leather, Orthopaedic design	WHEELER "Classic" Emerald Anatomic	VISCOUNT EMERALD GEL
SATTELSTUETZE	ALUTRAX Super Light Alloy 300mm	ALUTRAX Super Light Alloy 300mm	SR MTE Oversize
RAHMENHOEFFEN	17", 18 1/2", 20", 21"	17", 18 1/2", 20", 21"	17", 18", 20", 22"

TOP LINE

8200 DURA ACE MALCESINE



- MALCESINE**
AUSSTATTUNG : SHIMANO NEW DURA ACE 16 sp STI CONTROL LEVER
RAHMEN : TANGE "Champion No. 2" Double Butted, Investment Cast Lugs
GABEL : TANGE Cr-Mo, Investment Crown, Chrome
SCHALTGRUPPE : New DURA ACE STI
TRETLAGER : New DURA ACE 53/39T SUPERGLIDE
ZAHNKRANZ : HYPERGLIDE Cassette 12-21T 8 sp
NABEN : New DURA ACE
FELGEN : ARAYA PRO STAFF 340 or MAVIC GP4
BEREIFUNG : VITTORIA "CX"
SPEICHEN : Stainless D.B.
BREMSEN : New DURA ACE "SUPER SLR" W/STI Control Lever
STEUERSATZ : New DURA ACE
LENKERBUEGEL : MODOLO "X-TENOS" Hard Anodized
LENKERVORBAU : MODOLO "X-TENOS" Hard Anodized
SATTEL : WHEELER Leather
SATTELSTUETZE : SHIMANO DURA ACE
RAHMENHOEHEN : 50, 52, 54, 56, 58, 60, 62mm
 ★ ALSO AVAILABLE IN PURPLE/WHITE (BELOW)

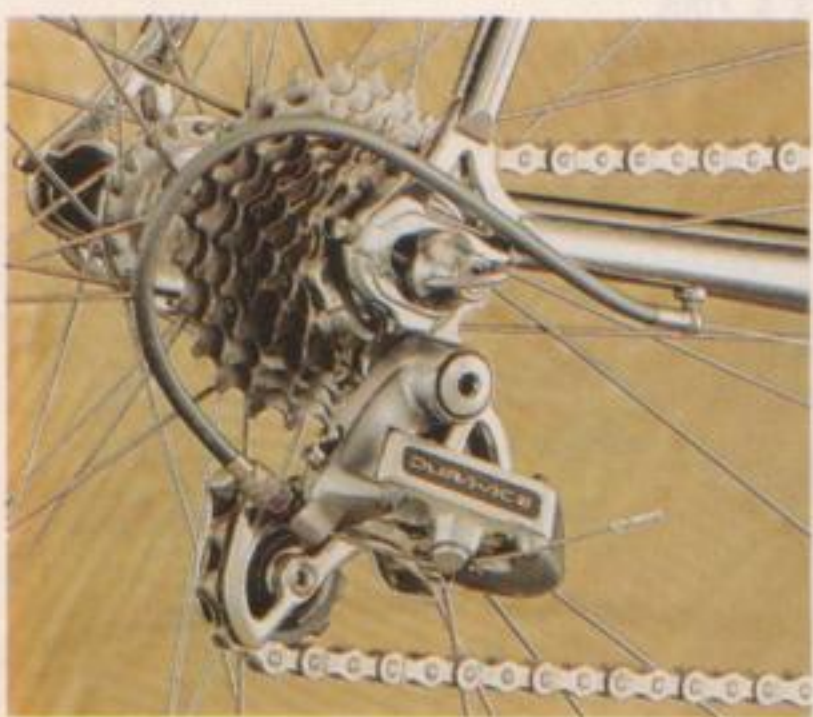

9990



- 9990**
AUSSTATTUNG : SHIMANO DEORE XT 21 sp
RAHMEN : ALUMINUM 7000 "Box stays", O.S. Tubing
GABEL : RESPONSE/TANGE O.S. Cr-Mo CP
SCHALTGRUPPE : DEORE XT TOP BAR SIS
TRETLAGER : DEORE XT 46/36/24T Round, SUPERGLIDE
ZAHNKRANZ : HYPERGLIDE 13-30T, 7s
PEDALE : DEORE XT Super Low Profile, Clips/Straps
NABEN : DEORE XT
FELGEN : ARAYA RM-17, SUPER Hard Anodized, 36H
BEREIFUNG : WHEELER "Mud Master" 26x2.00"
SPEICHEN : Stainless D.B.
BREMSEN : DEORE XT F/Canti, R/U-Brake, 2 finger lever
STEUERSATZ : WHEELER "Ultra Steer" Oversize Alloy
LENKERBUEGEL : WHEELER "Super Light" Special Alloy 560mm
LENKERVORBAU : ALUTRAX Alloy Superlight T.I.G.
LENKERGRIFFE : WHEELER Control Grips
SATTEL : SCHNEIDER Leather, Orthopaedic design
SATTELSTUETZE : ALUTRAX Super Light Alloy 300mm
RAHMENHOEHEN : 17", 18½", 20", 21"
 ★ SUNTOUR XC-PRO GREASE GUARD AVAILABLE AS IN PHOTO



MIKE KLUGE, GRUNDIG WORLD CUP CHAMPION, 1991 MIT WHEELER MOUNTAIN-BIKE UND MIT WHEELER RENNRAD.

1. DIE VERFUEGBAREN RAHMENHOEHEN, FARBEN, AUSSTATTUNGEN UND DAMENMODELLE ENTNEHMEN SIE BITTE DER AKTUELLEN PREISLISTE.
2. AUSSTATTUNGSÄNDERUNGEN VORBEHALTEN
3. ALLE RAEDER (AUSG. RENNRAEDER) SIND MIT KETTEN SCHUTZSCHEIBE (DIN NORM) AUSGESTATTET, BEI DEN HOCHWERTIGEN MODELLEN IST SIE LOSE BEIGELEGT.

COMP LINE



- 8800**
- AUSSTATTUNG : SHIMANO DEORE XT STI 21 sp
 - RAHMEN : TANGE "Prestige" O.S. MTB, O.S. Lugs, Chrome Stays
 - GABEL : RESPONSE Uni-crown TANGE Cr-Mo, Chrome
 - SCHALTGRUPPE : DEORE XT STI, Rapid Fire, TOP PULL
 - TRETLAGER : DEORE XT 46/36/24T Round, SUPERGLIDE
 - ZAHNKRANZ : HYPERGLIDE 13-30T, 7s
 - PEDALE : DEORE XT Super Low Profile, Clips/Straps
 - NABEN : DEORE XT
 - FELGEN : ARAYA RM-17, Super Hard Anodized, 36H
 - BEREIFUNG : WHEELER "Mud Master" 26x2.00"
 - SPEICHEN : Stainless
 - BREMSEN : DEORE XT Low Profile Canti, 2 finger lever
 - STEUERSATZ : WHEELER "Super Steer" Oversize 25.4mm
 - LENKERBUEGEL : WHEELER "Super Light" Special Alloy 560mm
 - LENKERVORBAU : ALUTRAX Alloy Superlight T.I.G.
 - LENKERGRIFFE : WHEELER Control Grips
 - SATTEL : SCHNEIDER Leather, Orthopaedic design
 - SATTELSTUETZE : ALUTRAX Super Light Alloy 300mm
 - RAHMENHOEHEN : 16", 18", 19½", 21"



- 8000**
- AUSSTATTUNG : SHIMANO DEORE XT STI 21 sp
 - RAHMEN : TANGE O.S. MTB Double Butted T.I.G.
 - GABEL : RESPONSE Uni-crown TANGE Cr-Mo
 - SCHALTGRUPPE : DEORE XT STI, Rapid Fire
 - TRETLAGER : DEORE XT 46/36/24T Round, SUPERGLIDE
 - ZAHNKRANZ : HYPERGLIDE 13-30T, 7s
 - PEDALE : WHEELER "Comp" Alloy, Clips/Straps
 - NABEN : DEORE XT
 - FELGEN : ARAYA CV-7, Anodized, 36H
 - BEREIFUNG : WHEELER "Mud Master" 26x2.00"
 - SPEICHEN : Stainless
 - BREMSEN : DEORE XT Low Profile Canti, 2 finger lever
 - STEUERSATZ : WHEELER "Super Steer" Oversize 25.4mm
 - LENKERBUEGEL : WHEELER Alloy 560mm, 5deg.
 - LENKERVORBAU : ULTRAX Cr-Mo Oversize 25.4mm T.I.G.
 - LENKERGRIFFE : WHEELER Control Grips
 - SATTEL : WHEELER "Classic" Emerald
 - SATTELSTUETZE : ALUTRAX Super Light Alloy 300mm
 - RAHMENHOEHEN : 16", 18", 19½", 21"



- 6800 ELEVATED CHAINSTAYS**
- AUSSTATTUNG : SHIMANO DEORE DX STI 21 sp
 - RAHMEN : TANGE O.S. MTB, Double Butted, T.I.G.
 - GABEL : RESPONSE Uni-crown TANGE Cr-Mo
 - SCHALTGRUPPE : DEORE DX STI, Rapid Fire
 - TRETLAGER : DEORE DX 46/36/24T Round, SUPERGLIDE
 - ZAHNKRANZ : HYPERGLIDE 13-30T, 7s
 - PEDALE : WHEELER "Comp" Alloy, Clips/Straps
 - NABEN : DEORE DX
 - FELGEN : ARAYA CV-7, Anodized, 36H
 - BEREIFUNG : WHEELER "Mud Master" 26x2.00" Black Wall
 - SPEICHEN : Stainless
 - BREMSEN : DEORE DX Low Profile Canti, 2 finger lever
 - STEUERSATZ : WHEELER "Super Steer" Oversize 25.4mm
 - LENKERBUEGEL : WHEELER Alloy 560mm, 5deg., w/BAR ENDZ
 - LENKERVORBAU : ULTRAX Cr-Mo oversize T.I.G. 18 deg
 - LENKERGRIFFE : WHEELER Control Grips
 - SATTEL : WHEELER "Classic" Emerald anatomic
 - SATTELSTUETZE : ALUTRAX Super Light Alloy 300mm
 - RAHMENHOEHEN : 18", 19½", 21"



RAHMENROHRE

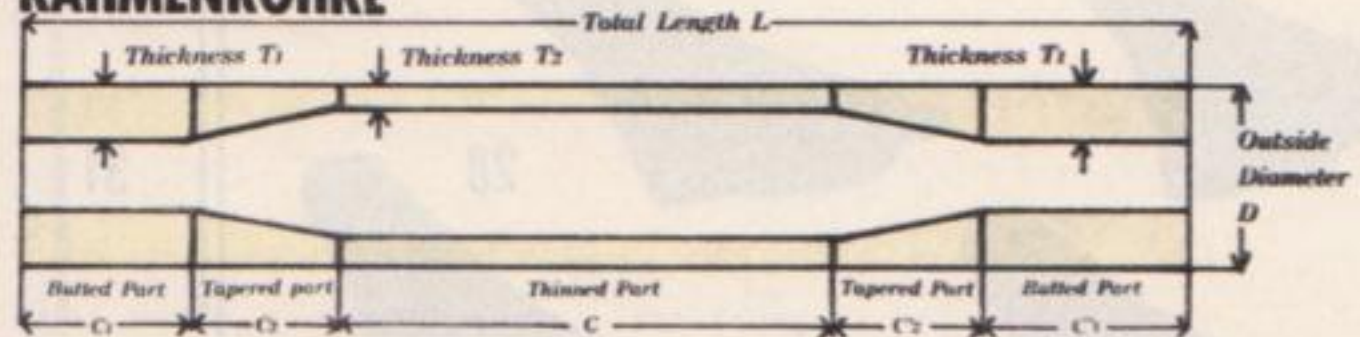

8800		T ₁ = 0.9mm	D _S /T = 31.8mm
		T ₂ = 0.6mm	D _T /T = 31.8mm
			D _D /T = 34.9mm
8000			
6800		T ₁ = 1.0mm	D _S /T = 31.8mm
6600		T ₂ = 0.7mm	D _T /T = 31.8mm
			D _D /T = 34.9mm

5500		T = 0.9mm	D _S /T = 31.8mm
			D _T /T = 31.8mm
			D _D /T = 34.9mm

COMP LINE



5500



8800



8000



6600



6800



5500L

RAHMENGEOMETRIE

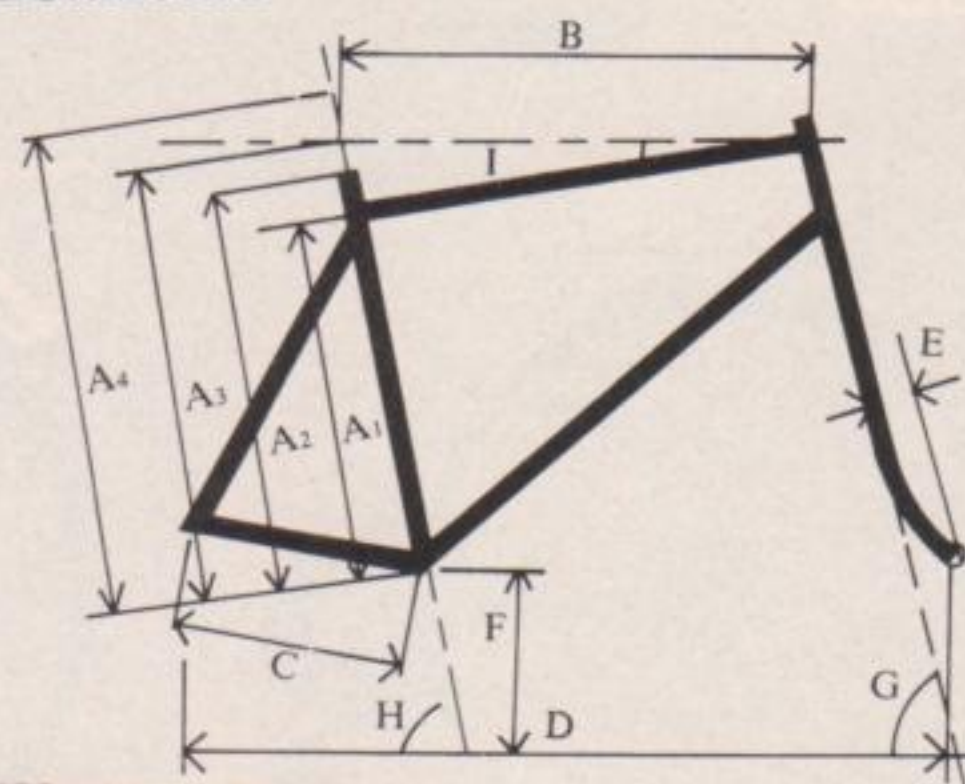

ALUMINIUM 9990, 9900, 7700

A2	A1	A2	A3	A4	B	C	D	E	F	G	H	I
21"	501	538	546	583	600	420	1071	45	300	71	73	4
20"	471	508	536	573	585	420	1067	45	300	71	73	5
18½"	433	470	508	545	575	420	1050	45	300	71	73	6
17"	393	430	505	542	565	420	1051	45	300	70	73	10

COMP LINE

A2	A1	A2	A3	A4	B	C	D	E	F	G	H	I
21"	504	531	546	573	600	426	1076	45	300	71	73	4
19½"	468	495	522	549	585	426	1069	45	300	71	73	5
18"	431	458	495	522	575	426	1052	45	300	71	73	6
16"	383	410	483	510	558	426	1029	45	300	71	73	10

PRO LINE

A2	B	C	D	E	F	G	H
22"	595	435	1087	45	300	71	73
20½"	585	435	1076	45	300	71	73
18"	565	435	1066	45	300	71	73
16"	550	435	1066	45	300	71	73

5500



5500

- AUSSTATTUNG** : SHIMANO DEORE LX STI 21 sp
RAHMEN : TANGE O.S. MTB Cr-Mo, O.S. Lugs
GABEL : RESPONSE Uni-crown TANGE Cr-Mo
SCHALTGRUPPE : DEORE LX STI, Rapid Fire
TRETLAGER : DEORE LX 46/36/24T Round, SUPERGLIDE
ZAHNKRANZ : HYPERGLIDE 13-30T, 7s
PEDALE : WHEELER "Comp" Alloy
NABEN : DEORE LX
FELGEN : ARAYA CV-7, Anodized, 36H
BEREIFUNG : WHEELER "Mud Master" 26x2.00"
SPEICHEN : Stainless
BREMSEN : DEORE DX Low Profile Canti
STEUERSATZ : WHEELER "Super Steer" O.S. 25.4mm
LENKERBUEGEL : WHEELER Alloy 560mm, 5deg.
LENKERVORBAU : ULTRAX Cr-Mo oversize T.I.G. 18 deg
LENKERGRIFFE : WHEELER Control Grips
SATTEL : WHEELER "Classic" Emerald Anatomic
SATTELSTUETZE : ALUTRAX Super Light Alloy 300mm
RAHMENHOEHNEN : 16", 18", 19½", 21" Ladies 18", 19½"

6600



6600

- AUSSTATTUNG** : SHIMANO DEORE DX STI 21 sp
RAHMEN : TANGE O.S. MTB, Double Butted, O.S. Lugs
GABEL : RESPONSE Uni-crown TANGE Cr-Mo
SCHALTGRUPPE : DEORE DX STI, Rapid Fire
TRETLAGER : DEORE DX 46/36/24T Round, SUPERGLIDE
ZAHNKRANZ : HYPERGLIDE 13-30T, 7s
PEDALE : WHEELER "Comp" Alloy, Clips/Straps
NABEN : DEORE DX
FELGEN : ARAYA CV-7, Anodized, 36H
BEREIFUNG : WHEELER "Mud Master" 26x2.00"
SPEICHEN : Stainless
BREMSEN : DEORE DX Low Profile Canti, 2 finger lever
STEUERSATZ : WHEELER "Super Steer" O.S. 25.4mm
LENKERBUEGEL : WHEELER Alloy 560mm, 5deg.
LENKERVORBAU : ULTRAX Cr-Mo oversize T.I.G.
LENKERGRIFFE : WHEELER Control Grips
SATTEL : WHEELER "Classic" Emerald Anatomic
SATTELSTUETZE : ALUTRAX Super Light Alloy 300mm
RAHMENHOEHNEN : 16", 18", 19½", 21"

PRO LINE

4500



4500
AUSSTATTUNG : SHIMANO 500 LX STI 21 sp
RAHMEN : TANGE MTB Cr-Mo, O.S. head Tube. T.I.G.
GABEL : RESPONSE Uni-crown TANGE Cr-Mo
SCHALTGRUPPE : 500 LX STI, Rapid Fire
TRETLAGER : 500 LX 46/36/24T Round, SUPERGLIDE
ZAHNKRANZ : HYPERGLIDE 13-30T, 7s
PEDALE : WHEELER Resin/Steel Composite
NABEN : SHIMANO 500 LX
FELGEN : ARAYA VP-20, Reinforced 36H
BEREIFUNG : WHEELER "Mitchell" 26x2.00"
SPEICHEN : Stainless
BREMSEN : SHIMANO Canti, 3 Finger Levers
STEUERSATZ : WHEELER "Super Steer" O.S. 25.4mm
LENKERBUEGEL : WHEELER Alloy 560mm, 5deg.
LENKERVORBAU : Cr-Mo Oversize T.I.G. 22 deg
LENKERGRIFFE : WHEELER Control Grips
SATTEL : WHEELER Emerald Anatomic
SATTELSTUETZE : Alloy 300mm
RAHMENHOEHEN : 16", 18", 20½", 22"

3500



3500/3600 ★
AUSSTATTUNG : SHIMANO 300LX STI 21sp
RAHMEN : TANGE MTB Cr-Mo, O.S. Head Tube, T.I.G.
GABEL : RESPONSE Uni-crown TANGE Cr-Mo
SCHALTGRUPPE : 300 LX STI, Rapid Fire
TRETLAGER : 300 LX 48/38/28 biopace, SUPERGLIDE
ZAHNKRANZ : HYPERGLIDE 13-30T, 7s
PEDALE : WHEELER Resin/Steel Composite
NABEN : SHIMANO 300 LX
FELGEN : ARAYA VP-20 Reinforced 36H
BEREIFUNG : WHEELER "Mitchell" 26x2.00"
SPEICHEN : Stainless
BREMSEN : SHIMANO Canti, 3 Finger Levers
STEUERSATZ : WHEELER "Super Steer" O.S. 25.4mm
LENKERBUEGEL : WHEELER Alloy 560mm, 5deg.
LENKERVORBAU : Cr-Mo oversize T.I.G. 22 deg
LENKERGRIFFE : WHEELER Control Grips
SATTEL : WHEELER Emerald Anatomic
SATTELSTUETZE : WHEELER Alloy 300mm
 ★ 3600 w/Fender, Carrier, Kickstand, Bell and Soubitez Light
RAHMENHOEHEN : 16", 18", 20½", 22" Ladies 18", 20½"



2000



2000/2100/1000 ★
AUSSTATTUNG : SHIMANO 200GS STI 21 sp
RAHMEN : TANGE MTB Cr-Mo, S.T. T.I.G.
GABEL : WHEELER Uni-crown
SCHALTGRUPPE : 200GS STI, Rapid Fire
TRETLAGER : 200GS 48/38/28 Biopace, SUPERGLIDE
ZAHNKRANZ : HYPERGLIDE 13-30T, 7s
PEDALE : Resin
NABEN : SHIMANO 200
FELGEN : ARAYA VP-20, Reinforced 36H
BEREIFUNG : WHEELER "Galibier" 26x2.00"
SPEICHEN : Stainless
BREMSEN : SHIMANO Canti, 3 Finger Levers
STEUERSATZ : WHEELER "Sealed" Off-road type
LENKERBUEGEL : WHEELER Alloy 560mm, 5deg.
LENKERVORBAU : SR Sakae Alloy
LENKERGRIFFE : WHEELER Control Grips
SATTEL : WHEELER Emerald Anatomic
SATTELSTUETZE : Alloy 300mm
 ★ 2100 w/Fender, Carrier, Kickstand, Bell and Soubitez Light
 1000 W/SHIMANO 100STI
RAHMENHOEHEN : 16", 18", 20½", 22" Ladies 18", 20½"

CROSS LINE

7000



7000
AUSSTATTUNG : SHIMANO DEORE XT STI 21 sp
RAHMEN : TANGE MTB Double Butted Lugged, Chrome Stays
GABEL : RESPONSE Uni-crown TANGE Cr-Mo, Low-rider boss
SCHALTGRUPPE : DEORE XT STI, Rapid Fire
TRETLAGER : DEORE XT 46/36/24T Round, SUPERGLIDE, SKF
ZAHNKRANZ : HYPERGLIDE 13-30T, 7s
PEDALE : DEORE XT Super Low Profile, Clips/Straps
NABEN : DEORE XT
FELGEN : MAVIC Module 4, 700C, hard Anodized, 36H
BEREIFUNG : WHEELER "Cross Master" 700x43C
SPEICHEN : Stainless
BREMSEN : DEORE XT Low Profile Canti, 2 finger lever
STEUERSATZ : WHEELER "Super Steer" Oversize 25.4mm
LENKERBUEGEL : WHEELER "Super Light" Special Alloy 560mm w/BAR ENDZ
LENKERVORBAU : ALUTRAX Alloy Superlight T.I.G. 120/135mm
LENKERGRIFFE : WHEELER Control Grips
SATTEL : SCHNEIDER Leather, Orthopaedic design
SATTELSTUETZE : ALUTRAX Super Light Alloy 300mm
RAHMENHOEHEN : 18½", 21", 22", 23"

6000

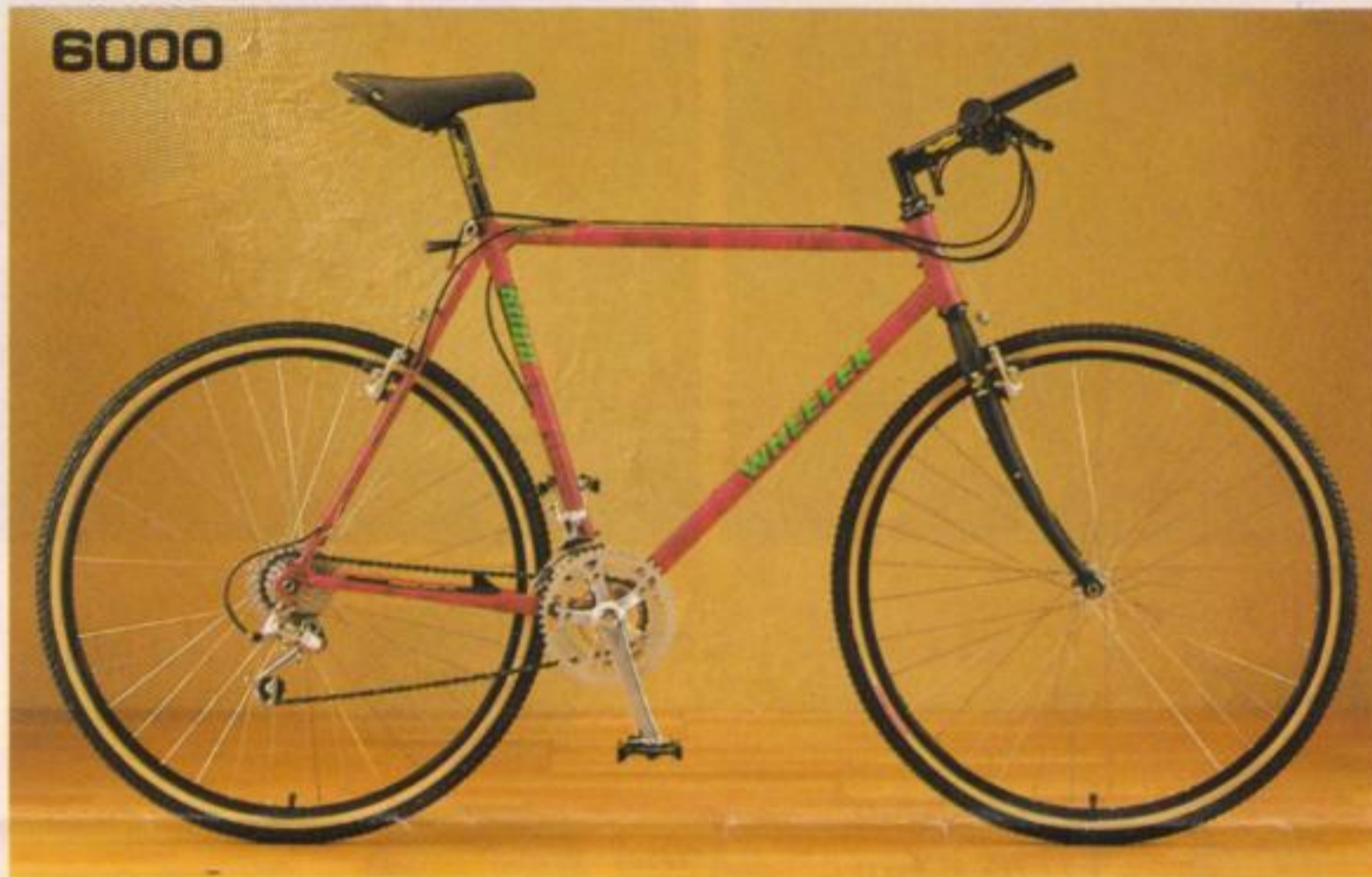

6000
AUSSTATTUNG : SHIMANO DEORE DX STI 21 sp
RAHMEN : TANGE MTB Cr-Mo, O.S. Head Tube, Lugged
GABEL : RESPONSE Uni-crown TANGE Cr-Mo, Low-rider boss
SCHALTGRUPPE : DEORE DX STI, Rapid Fire
TRETLAGER : DEORE DX 46/36/24T Round, SUPERGLIDE, SKF
ZAHNKRANZ : HYPERGLIDE 13-30T, 7s
PEDALE : WHEELER "Comp" Alloy
NABEN : DEORE DX
FELGEN : MAVIC Module 4 700C, hard Anodized 36H
BEREIFUNG : WHEELER "Cross Master" 700x43C
SPEICHEN : Stainless
BREMSEN : DEORE DX Low Profile Canti
STEUERSATZ : WHEELER "Super Steer" O.S. 25.4mm
LENKERBUEGEL : WHEELER Alloy 560mm, 5deg. w/BAR ENDZ
LENKERVORBAU : ULTRAX Cr-Mo Oversize T.I.G. 120/140mm
LENKERGRIFFE : WHEELER Control Grips
SATTEL : WHEELER "Classic" Emerald Anatomic
SATTELSTUETZE : ALUTRAX Super Light Alloy 300mm
RAHMENHOEHEN : 18½", 21", 22", 23"

5000



5000/5100 ★
AUSSTATTUNG : SHIMANO DEORE LX STI 21 sp
RAHMEN : TANGE MTB Cr-Mo, O.S. Head Tube. Lugged
GABEL : RESPONSE Uni-crown TANGE Cr-Mo, Low-rider boss
SCHALTGRUPPE : DEORE LX STI, Rapid Fire
TRETLAGER : DEORE LX 46/36/24T Round, SUPERGLIDE, SKF
ZAHNKRANZ : HYPERGLIDE 13-30T, 7s
PEDALE : WHEELER "Comp" Alloy
NABEN : DEORE LX
FELGEN : ARAYA VX-300,700C, Hard Anodized, 36H
BEREIFUNG : WHEELER "Cross master" 700x43C
SPEICHEN : Stainless
BREMSEN : DEORE DX Low Profile Canti
STEUERSATZ : WHEELER "Super Steer" O.S. 25.4mm
LENKERBUEGEL : WHEELER Alloy 560mm, 5deg.
LENKERVORBAU : ULTRAX Cr-Mo Oversize T.I.G. 120/140mm
LENKERGRIFFE : WHEELER Control Grips
SATTEL : WHEELER "Classic" Emerald Anatomic
SATTELSTUETZE : ALUTRAX Super Light Alloy 300mm
RAHMENHOEHEN : 18½", 21", 22", 23" Ladies 18½", 21"

★ 5100 AVAILABLE WITH SUNTOUR XC-LTD ★ LAVENDER BLUE AVAILABLE

3000



3000/3100 ★
AUSSTATTUNG : SHIMANO 300LX STI
RAHMEN : TANGE MTB Cr-Mo, O.S. Head Tube. Lugged
GABEL : RESPONSE Uni-crown TANGE Cr-Mo, Low-rider boss
SCHALTGRUPPE : 300 LX STI, Rapid Fire
TRETLAGER : 300 LX 48/38/28 Biopace, SUPERGLIDE, SKF
ZAHNKRANZ : HYPERGLIDE 13-30T, 7s
PEDALE : WHEELER Resin/Steel Composite
NABEN : SHIMANO 300 LX
FELGEN : ARAYA PX-45 700C
BEREIFUNG : WHEELER "Cross Master" 700x43C
SPEICHEN : Stainless
BREMSEN : SHIMANO Canti, 3 Finger Levers
STEUERSATZ : WHEELER Sealed offroad type
LENKERBUEGEL : WHEELER Alloy 560mm, 5deg.
LENKERVORBAU : ULTRAX Cr-Mo T.I.G. 120/140mm
LENKERGRIFFE : WHEELER Control Grips
SATTEL : WHEELER Emerald Anatomic
SATTELSTUETZE : Alloy 300mm
 ★ 3100 w/Carrier, Fenders, Kickstand,
 Bell and Soubitez Light
RAHMENHOEHEN : 18½", 21", 22", 23" Ladies 18½", 21"

RACING

7200 CHIOSTRA



- 7200**
AUSSTATTUNG : SHIMANO 600 "Ultegra" 14 sp
RAHMEN : TANGE "Champion No. 2" Double butted Investment Cast Lugs
GABEL : TANGE Cr-Mo, Aero Investment Crown
SCHALTGRUPPE : SHIMANO 600
TRETLAGER : SHIMANO 600 52/42T Superglide
ZAHNKRANZ : HYPERGLIDE 13-23T, 7s
NABEN : SHIMANO 600
FELGEN : MAVIC 192FB 700C
BEREIFUNG : VITTORIA "Zefir" 700x19C
SPEICHEN : Stainless
BREMSEN : SHIMANO 600 Super SLR
STEUERSATZ : SHIMANO 600
LENKERBUEGEL : SR "Modolo Bend" 39/41/43cm
LENKERVORBAU : Alloy 80/100/120mm
SATTEL : WHEELER Leather
SATTELSTUETZE : SHIMANO 600
RAHMENHOEHEN : 50, 52, 54, 56, 58, 60, 62cm

RAHMENROHRE

7200  T₁ = 0.9mm
T₂ = 0.6mm

6200  T₁ = 0.9mm
T₂ = 0.6mm

4200  T = 0.9mm
3200 

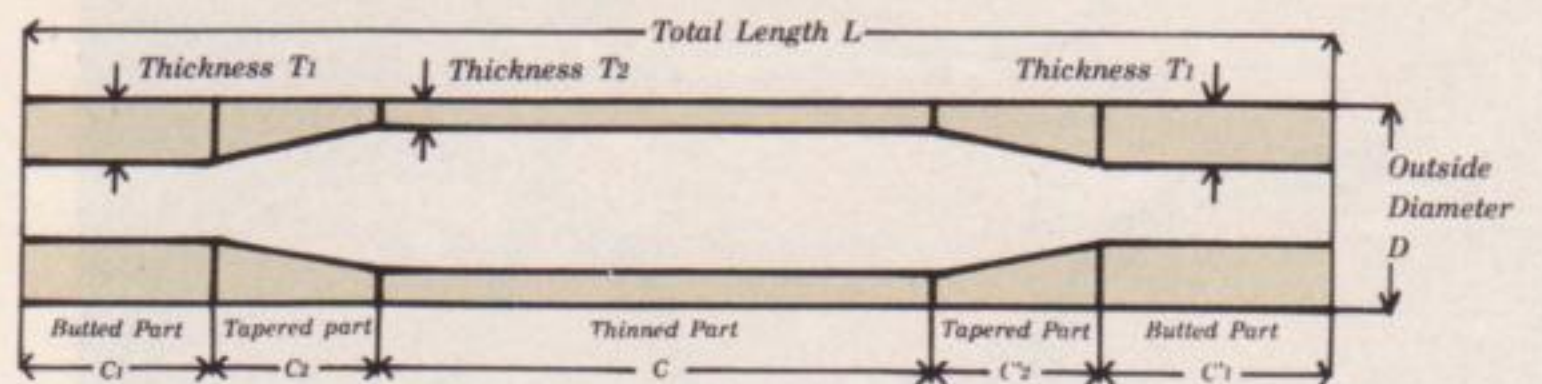

RAHMENGEOMETRIE

RACING

A	B	C	D	E	F	G	H
50	530	410	968	45	280	73.5	73.5
52	545	410	972	45	277	74	73.5
54	545	410	972	45	270	74	73.5
56	560	410	985	45	270	74	73.5
58	570	410	994	45	270	74	73.5
60	580	410	1003	45	270	74	73.5
62	580	410	1003	45	270	74	73.5

CROSS

A	A	B	C	D	E	F	G	H
23"	590	605	435	1088	45	305	71	73
22"	565	595	435	1078	45	305	71	73
21"	535	585	435	1067	45	305	71	73
18½"	473	565	435	1061	45	305	71	73

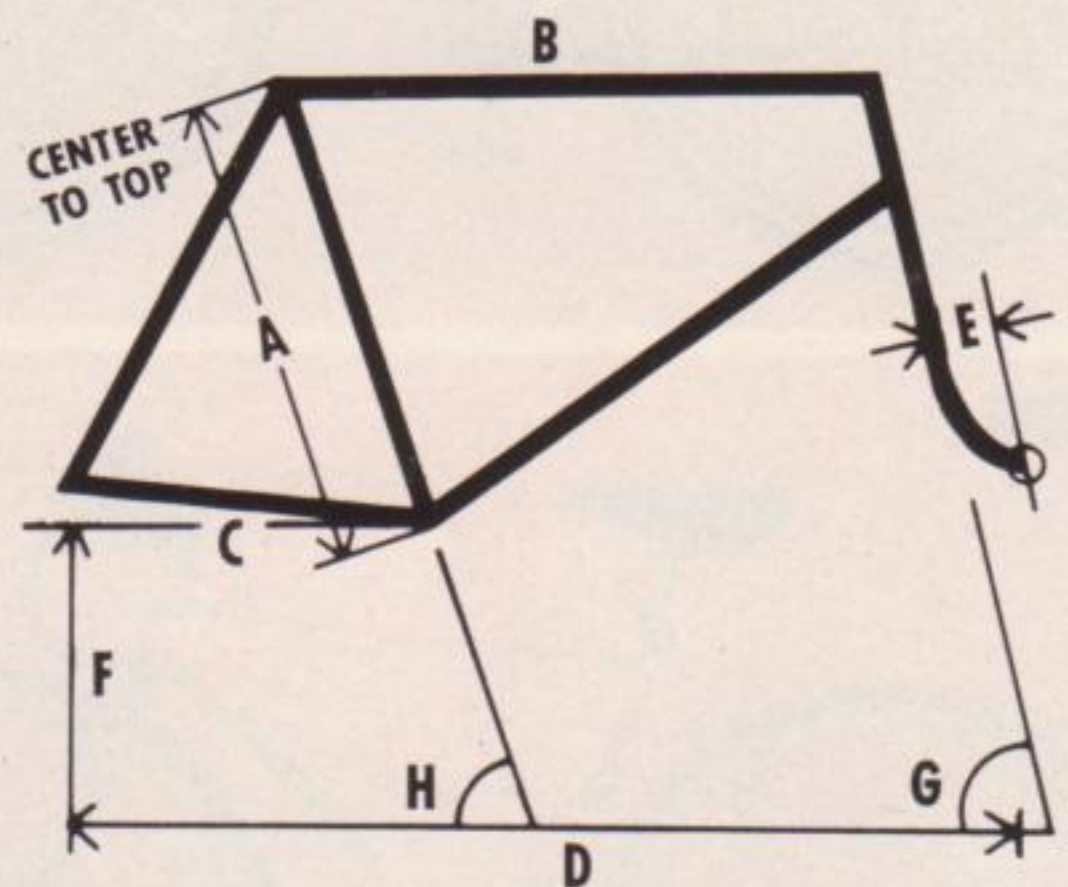

TREKKING

A	A	B	C	D	E	F	G	H
23"	585	605	435	1087	45	295	71	73
22"	560	595	435	1076	45	295	71	73
21"	530	585	435	1066	45	295	71	73
18½"	474	565	435	1061	45	295	71	73

RACING

6200 TREMOSINE



6200	
AUSSTATTUNG	: SHIMANO NEW 105 14 sp
RAHMEN	: TANGE "Infinity" Double Butted Investment Cast Lugs, Chrome Stays
GABEL	: TANGE Cr-Mo, Aero Investment Cast Crown, Chrome
SCHALTGRUPPE	: SHIMANO 105
TRETLAGER	: SHIMANO 105 42/52T, Round, Superglide
ZAHNKRANZ	: HYPERGLIDE 13-23T, 7s
NABEN	: SHIMANO 105
FELGEN	: MAVIC 192FB 700C
BEREIFUNG	: VITTORIA "Zefir" 700x19C
SPEICHEN	: Stainless
BREMSEN	: SHIMANO Super SLR
STEUERSATZ	: SHIMANO 105
LENKERBUEGEL	: SR "Modolo Bend" 39/41/43cm
LENKERVORBAU	: Alloy 80/100/120mm
SATTEL	: WHEELER Leather
SATTELSTUETZE	: Alloy 250mm
RAHMENHOEHEN	: 50, 52, 54, 56, 58, 60, 62cm



MIKE KLUGE



4200 DESENZANO



4200	
AUSSTATTUNG	: SHIMANO RX100 14 sp
RAHMEN	: TANGE No. 5 Cr-Mo, Lugged, Chrome Stays
GABEL	: TANGE Cr-Mo sloping crown, Chrome
SCHALTGRUPPE	: SHIMANO RX100
TRETLAGER	: RX100 42/52 Round Superglide
ZAHNKRANZ	: HYPERGLIDE 13-23T, 7s
PEDALE	: Alloy Clips/Straps
NABEN	: SHIMANO RX100
FELGEN	: MAVIC 192FB 700C
BEREIFUNG	: VITTORIA "Zefir" 700x19C
SPEICHEN	: Stainless
BREMSEN	: SHIMANO RX100 Super SLR
STEUERSATZ	: SHIMANO RX100
LENKERBUEGEL	: SR "Modolo Bend" 39/41/43cm
LENKERVORBAU	: Alloy 80/100/120mm
SATTEL	: WHEELER Emerald
SATTELSTUETZE	: Alloy 250mm
RAHMENHOEHEN	: 50, 54, 56, 58, 62cm

3200 SIRMIONE



3200	
AUSSTATTUNG	: SHIMANO 300EX 14 sp
RAHMEN	: TANGE No. 5 Cr-Mo, Lugged
GABEL	: TANGE Cr-Mo sloping crown, Chrome
SCHALTGRUPPE	: SHIMANO 300EX
TRETLAGER	: 300EX 42/52 Round
ZAHNKRANZ	: HYPERGLIDE 13-23T, 7s
PEDALE	: Resin Composite, Clips/Straps
NABEN	: SHIMANO 300EX
FELGEN	: MAVIC 192FB 700C
BEREIFUNG	: VITTORIA "Zefir" 700x19C
SPEICHEN	: Stainless
BREMSEN	: SHIMANO 300EX SLR
STEUERSATZ	: SHIMANO 300EX
LENKERBUEGEL	: SR "Modolo Bend" 39/41/43cm
LENKERVORBAU	: Alloy 80/100/120mm
SATTEL	: WHEELER Emerald
SATTELSTUETZE	: Alloy 250mm
RAHMENHOEHEN	: 50, 54, 56, 58, 62cm